



February 2024

Commodore's Corner, Zack Lawson



Ahoy, Sailors! Spring Sails In with Winter Pursuit Race!

Last weekend, our sailing club came alive with excitement as we took to the wintry waters for a pursuit race! Picture this: colorful sails dotted the horizon as sailors vied for position in the chilly breeze.

In the midst of the competition, a playful gust of wind gave a struggling boat a boost, much to the amusement of all. It was a reminder that even nature enjoys a good laugh now and then.

But what truly warmed our hearts was seeing sailors of all ages coming together, bound by their love for the sea and the thrill of the race. As we welcome spring and look forward to sunnier days ahead, let's cherish the camaraderie that makes our sailing club feel like home. Smooth sailing, everyone!

Zack Lawson Commodore, BCSA

Vice Commodore, Matt Birkbickler



Ahoy, Sailors!

As we navigate through the chilly waters of February, it's time to warm up and a recap of our recent escapades at the sailing club. I'm your Vice Commodore, and if you haven't heard my name yet, well, that's okay.

Let's kick things off with a hearty round of applause for surviving the first Frostbite Series race! While no one broke any speed records, we did manage to keep Pat away from any bridge—a monumental feat, if you ask me. Rumor has it the course was nowhere near the bridge, but Pat was nowhere near to course, so there's that.

Mystery Night and Soup Social—a night where clues were as plentiful as the ladleful of soup. Congratulations to Jeff, Carol, and Emma for unravelling the mystery! I must admit, I'm still trying to figure out how they deduced the culprit from a spilled bowl of cheeseburger soup, but that's a mystery for another night.

In other news, it seems our beloved Hobby Bravo is taking a well-deserved vacation at the repair shop. Don't worry, little dinghy, we'll have you sailing again in no time!

Now, onto the less glamorous—but equally important—matters: volunteer opportunities. Yes, I'm looking at you, fellow sailors! We need all hands-on deck for boat maintenance, Inventory, and clean-up duty. From scrubbing Catalina 22s top to bottom to giving our committee boat a much-needed spa day, there's a task for everyone. And let's not forget about the poor Sunfish dinghies—those little guys could use some TLC too. We need someone to assemble and take an inventory of sails, hulls, and a parts replacement list. If you're feeling extra adventurous, we even have a motor replacement project that could use your expertise. Just think of it as a “General Recall” for our boat—only this time, we're swapping out engines instead of a race committee.

For those brave souls willing to embark on these noble journeys, please reach out to Matt Brickbichler. And remember, the more the merrier!

As we bid adieu to February and set our sights on warmer waters, let's keep the laughter flowing and the sails billowing. After all, it's not just about the destination—it's about the hilarious mishaps and unforgettable memories we make along the way.

Until next time, may your jokes be as cheesy as a bowl of soup at Mystery Night.

Fair winds,

Matt Birckbichler Vice Commodore, Chief Soup Connoisseur, and Bridge Avoidance Specialist

Treasurer and Membership Chair,

Elizabeth Starnes

Thanks to those who have renewed memberships or joined BCSA as new members this year. For those who have not, **we ask that dues be paid by February 1 each year. After that the door code will be changed.** We have a new Commodore and new officers with lots of activities planned for the year. I hope you will send in your membership dues - only \$150 - and take advantage of all the club has to offer.

Checks can be mailed to BCSA -100 Browns Creek Rd - Guntersville, AL 35976; put cash or check in the lock box by the door; or with PayPal - \$155 for processing fee. If paying with PayPal, be sure to include an email so we can put you on our list for the newsletter and information on upcoming events. PayPal: brownscreekmembership@gmail.com

We're off to a great start this year with 54 members. I hope everyone takes advantage of all the club has to offer.



Elizabeth Starnes Photo

Ed Note: Our esteemed Treasurer is in Key Largo. She did take a few minutes out of her travel itinerary to send us the newest membership count! Although of few words, she hit the major point. BCSA has lots of offer. It's a great deal. Access to all the Clubhouse, the Dinghy's and Keelboats, the Parties, the instruction, and the camaraderie of all the members are well worth the fee. I've noticed in the past a lot of our members form lifelong relationships due to their participation.

Communications: BCSA utilizes several modes of Communications. By our constitution, all *official* communications between the board and the membership, is through the Drifter.

Additionally, BCSA maintains a Facebook Page, at Browns Creek Sailing Association,



and BCSA maintains a webpage at



www.BrownsCreekSailingAssociation.org/wordpress

Race Chair, Chris Edwards 

Notice of Race



Celebrate St. Patrick's Day with us on March 16th, kicking off at 5pm, right after the Pints and Patties Regatta! Enjoy live music by Hard on the Chickens from 6:30pm to 8:30pm. Don't forget to bring some pints for sharing. We'll be serving up a feast of patty melts and a variety of side dishes. Make sure to dress in green and join us for an evening filled with festivity and joy. See the schedule of events below in the NOR.

Notice of Race

February 17, 2024

St. Patrick's Day Regatta 2024

The race shall be governed by the World Sailing Rules of Racing 2021-2024. The 2014 Portsmouth Handicapping System shall be employed to handicap this event with wind, spinnaker, prop, and headsail adjustment factors. All Sailing Yachts shall be eligible for entry and shall be handicapped accordingly. Skippers meeting at 10:00 at BCSA clubhouse, [105 Browns Creek Rd. Guntersville, AL](#). Races warning signal to be made at approximately 11:00 in the region of Lower Guntersville Light (LGL). We are following the standard [BCSA Sailing Instructions](#), which are located on BCSA's website. Expected Fleets: Dinghy, Keelboat and Cruiser.

Schedule of Races: Three Races are scheduled, however one race will constitute a regatta. No races will be started after 16:00 on Saturday. No throw outs.

Schedule of Events:

Saturday 09:00 Registration Opens
March 16th: 10:00 Registration Closes

11:00 Committee Meeting
12:00 First Race in vicinity of LGL
16:00 No Race Begins afterward
17:00 Dinner
18:00 Awards
18:30 After Party with live music by "Hard on the Chickens".

Sunday Alternate Day to Race if Saturday's weather is a bust with the same
March 17th: schedule. Social will happen on Saturday no matter the weather.

Trophies: Will be awarded to the top three skippers and crew of each fleet.

Fees: Regatta Entry \$25.00 - includes one dinner Additional Dinner – Patty Melts & Sides \$10.00 each

Classes: Race committee has sole discretion to move any boat to any class and to combine classes, this shall not be grounds for protest or redress.

Registration: <https://nextsailor.com/app/page/regatta/638>

Dinner RSVP Only: <https://brownscreeksailingassociation.org/wordpress/ppec-products/pints-patties-st-patrick-day-dinner/>

Contact: Chris Edwards

Event	Race Type	RC PRO	RC Assistant	Day	Start Date	End Date
Racing 101 Part 1	Class			Saturday	3/2/2024	10:00 AM
Frostbite Series 1 Race #3	Pursuit			Sunday	3/3/2024	2:00 PM
St. Patrick's Day Regatta	Buoy	Chris Edwards	Sherri Walls, Eric Jackson	Saturday	3/16/2024	1:00 PM
Racing 101 Part 2	Class			Saturday	3/23/2024	10:00 AM
Spring Series Race #1	Buoy	Susan Wilson	Linda Pope, Steven Harrigan	Sunday	3/24/2024	3:00 PM
Spring Series Race #2	Pursuit			Sunday	4/7/2024	3:00 PM
Swap The Tiller Regatta @ BCSA				Saturday	4/13/2024	1:00 PM
Spring Series Race #3	Buoy	Ed Hurst	Andrew McDowell, David Carstens	Sunday	4/14/2024	3:00 PM
Spring Series Race #4	Pursuit			Sunday	4/21/2024	3:00 PM
Guntersville Cup@LGSC	Buoy			Friday & Saturday	4/19/24-4/20/24	TBD
Spring Series Race #5	Buoy	Chris Edwards	Jeffery Wilson	Sunday	4/28/2024	3:00 PM
Spring Series Race #6	Pursuit			Sunday	5/5/2024	3:00 PM
Mayor's Cup	Buoy	Dave Ellis, T Willson	Allyson Lewter	Saturday	5/18/2024	12:00 PM
Spring Series Race #7	Buoy	Susan Moser	Bruce Mitchell	Sunday	6/2/2024	3:00 PM
Swap The Tiller Regatta @ LGSC				Saturday	6/8/2024	1:00 PM
Spring Series Race #8	Pursuit			Sunday	6/9/2024	3:00 PM
Animal Cracker Regatta	Buoy	Greg Bennett	Mark Proctor, Donnie George	Saturday	6/22/2024	1:00 PM
Spring Series Race #9	Pursuit			Sunday	7/14/2024	3:00 PM
Spring Series Race #10	Pursuit			Sunday	7/21/2024	3:00 PM
Fall Series Race #1	Buoy	Andy Myrick	Keith Hall	Sunday	7/28/2024	3:00 PM
Fall Series Race #2	Pursuit			Sunday	8/4/2024	3:00 PM
Fall Series Race #3	Buoy	David Chadwick	Bea Picou	Sunday	8/11/2024	3:00 PM
Fall Series Race #4	Pursuit			Sunday	8/18/2024	3:00 PM
Fall Series Race #5	Buoy	Matt Birckbichler	Jenn Birckbichler	Sunday	8/25/2024	3:00 PM
Fall Series Race #6	Pursuit			Sunday	9/8/2024	3:00 PM
Fall Series Race #8	Buoy	Zack Lawson	Julie Lawson	Sunday	9/15/2024	3:00 PM
Fall Series Race #9	Pursuit			Sunday	9/22/2024	3:00 PM

TVCC	Buoy	Butch Starnes	Elizabeth Starnes, Ken Atchison	Friday, Saturday & Sunday	9/27/2024	3:00 PM
Fall Series Race #10	Pursuit			Sunday	10/6/2024	3:00 PM
Fall Series Race #11	Pursuit			Sunday	10/13/2024	3:00 PM
Great River Race	Buoy	Monty Williams	Pat Upton	Saturday & Sunday	10/19/2024	10:00 AM
Halloween Regatta	Buoy	Ed Hurst	Margaret Hurst, Dallas Mayo	Saturday	10/27/2024	1:00 PM
Frostbite Series 2 Race #1	Pursuit			Sunday	11/3/2024	2:00 PM
Frostbite Series 2 Race #2	Pursuit			Sunday	11/17/2024	2:00 PM
Frostbite Series 2 Race #3	Pursuit			Sunday	12/8/2024	2:00 PM

Education Chair, Susan Wilson

BCSA Sailing 101 Spring Class Launches from North Alabama Sailing Marina Guntersville, AL



April 27, 28, May 4, 5, 2024

- **Class meets 10 am- 4 pm Saturdays and 1 pm-4 pm Sundays**
- **Saturday schedule: 10 am- noon classroom sailing basics**
 - Noon- lunch on the deck**
 - 1pm- 4 pm sailing training on helm and crew with instructor on board**
- **Sunday schedule: 1 pm- 4 pm sailing training on helm and crew with instructor on board**
- **Students need to attend all four days of instruction and bring a Type III life vest**
- **\$250/\$350 couple, class fee includes 2024 BCSA membership**

Class size is limited

Message Susan Wilson on Facebook

Send check payable to BCSA to Susan Wilson, 100 Browns Creek Road, Guntersville, AL 35976



BCSA Education:

Sailing 101- BCSA Sailing 101 Class is April 27, 28, May 4, 5. This is always a well-attended class and it fills up fast. It's early January as I write this, and we already have six students signed up. The class limit is 12 students. If you know someone that is interested have them sign up soon by messaging me on Facebook or email me.

Before class we need members to get the boats and clubhouse ready for our new sailors. We will get this started in March. Some of the jobs you can help with are:

Clean BCSA clubhouse, clean club Catalina 22's inside and out, check boats rigging and motors, and help with the graduation social. VC Matt Birckbichler will coordinate the boat prep and Jennifer will coordinate the social. Let us know what you would like to help with.

Youth Sailing-Sailing Parents: Let me know if you can help with some Youth Sailing training. I'm looking for calendar dates that would work for our middle school aged BCSA sailors. We have five Open Skiffs and Seven Sunfish available. Message me through Facebook or email me. We will need parents to help with rigging and chase boats.

Racing Seminar-Want to start racing but don't know where to begin? Want to improve your starting tactics? While the skies are dark and cold let's start off the year discussing four seminars put out by North U through American Sailing. North U says: "This series of four online classes teach the strategy and tactics you need to turn your speed into a podium finish." I'm in!

I'm planning this to be an open forum: discuss tactics, ask questions. Any level of racer/crew are welcome, from novice to experienced winner.

March 2, 1 pm

Session 1: Starting Strategy and Tactics / Upwind Strategy and Tactics

March 23, 1pm

Session 2: Mark Roundings, Finishing and Rules/ Downwind Strategy and Tactics

Cruise Chair, Mark Proctor



Ed Note: Our esteemed Cruise Committee has got a new boat. This Hunter Giant something, rumored to be fast, is consuming all his time. He has hinted at a cruise next month.

Social Chair, Jennifer Birkbickler



The February social event was a hit, featuring eight types of soup and an exciting mystery game. Attendees enjoyed bonding over delicious soups, and immersing themselves in the thrilling mystery plot. With the culprit eventually revealed, the atmosphere shifted to one of shared triumph and camaraderie. The event highlighted the importance of community and left everyone eagerly anticipating future gatherings.

Come on out for our next social march 16th for St. Patty's pints and patty melts. More info to be emailed soon.

Jennifer Birckbichler Social Chair

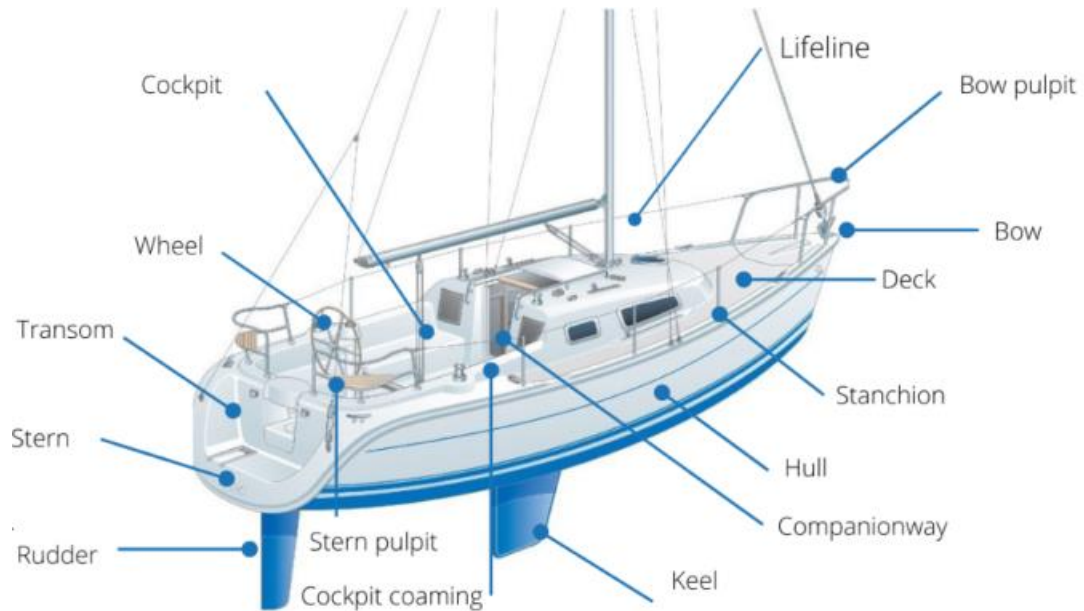

Secretary, Ed Hurst

We've had a good start to the new year. We had the RC class, two pursuit races, and 3 parties.

This year we have a new RC officer, Chris Edwards, who is enthusiastic and has provided an active, and somewhat novel, schedule for the racers. Lots of Racing! The schedule along with committee assignments is attached.



Houston Bridge, Michael Kirkpatrick photo

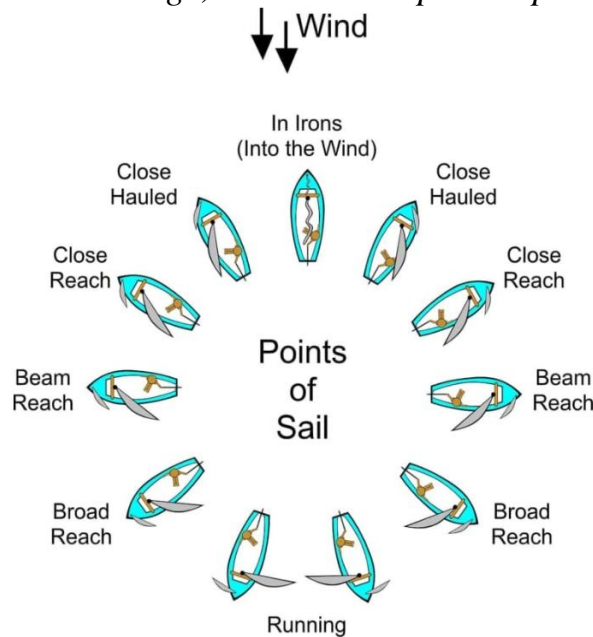

spitball verb

spitballed; spitballing

transitive + intransitive

informal

: to propose (ideas, suggestions, etc.) for consideration in an informal, preliminary way

Writers *spitballed* story ideas; editors dreamed up coverage

Virgin Islands

From the last issue of the Drifter, I had a short story about Margaret and I chartering a Bareboat Jeanneau 370 in the BVI back in October. It's typically every sailor's dream to do the BVI or the Bahamas. The Bahamas is closer, but you have to cross the Gulf Stream and I don't believe the Abacos, the outer Island sailing area has recovered from the Hurricane. I did the Bahamas in 1982, I flew into Marsh Harbor and spent 10 days on a 40 Ft monohull. It was fun, but not the BVI.

We've been talking about going back possibly setting up a flotilla if there is any interest. But this is by no way the first visit of a BCSA sailor to the BVI. Dave Carstens kept a Jeanneau there and sailed extensively

among the Islands.

But also, back in 1997, BCSA sailors had a group flotilla whereas they chartered several large boats. I think there were around 30 sailors participating. Unfortunately, without me!

I've included a past drifter, (may1997) in the back which has a couple of articles by Bill Stevens and Amy Gonzales. Amy was the event coordinator. Typically, this person gets their charter, at least part, at a discount or free. Sounds good until you consider you have to herd all these "A" type cats. We would need another Amy.

I think we should go again, somewhere in 2025/2026 not in Hurricane Season- June -November. Incidentally Lobster season opens 1st of November and the Trades start, (20-25 knots).

Interested? Think about it and let us know.



Note: The Virgin Islands (USA) is not shown on this map. The Distance between the western end of Tortola, Little Thatch key and Norman Island, is only about a mile.



*Ed-I see all the Youtube sailors drinking Caribe Beer.
But I noticed the locals, and I, seem to prefer Red-Stripe - from Jamaica mon!*

Sailing Stories by the Fire



March

www.davefostercomics.com

© 2015 Dave Foster

6:1 Double-Ended Cascaded Kicker - Boom Vang System

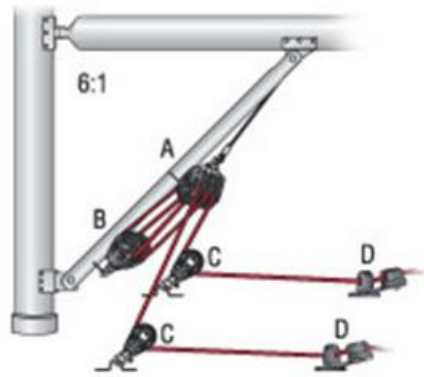

Note: this has nothing to do with any content. Of interest, at least to the editor, because it's a double ended Vang. This is seen on a lot of Dinghy's so that you can control the mainsail twist from the weather rail. This is helpful so that you can controll the sail while keeping your weight out.

<https://www.northalabamasailing.com>

A screenshot of the website northalabamasailing.com. The header features a compass rose logo with the text 'SAILING MARINA' on the left and navigation links 'HOME', 'VACATION RENTALS', and 'SAILING CLUB' on the right. A large red arrow points to a blue button that says 'BEST SAILING IN THE SOUTH' with a sub-link 'CURRENT WEATHER CONDITIONS NASM'. Below the header is an aerial photograph of a marina with several blue-roofed buildings, a parking lot, and a boat ramp along a body of water.

Don Moser set up a nifty local weather site at the Marina.
First navigate to [northalabamasailing.com](https://www.northalabamasailing.com) site.
Click the Current Weather Conditions.

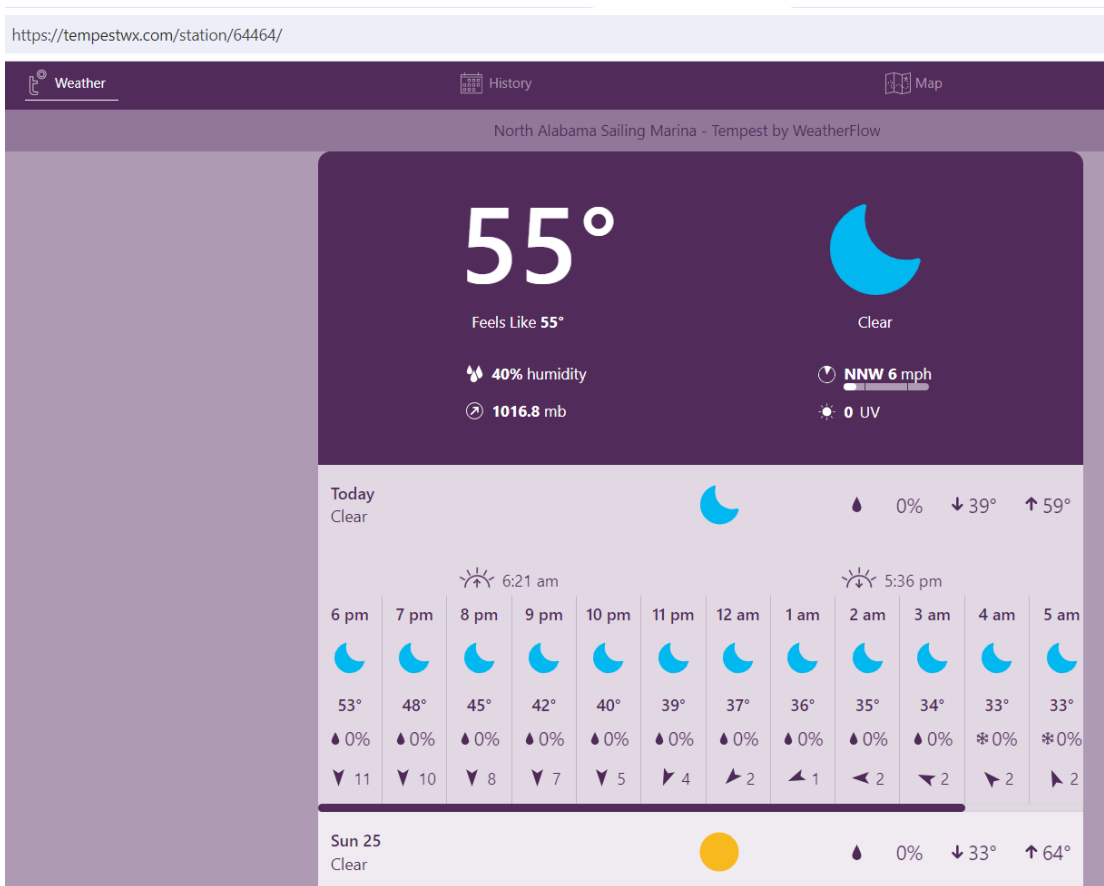







This will bring you to the weather page which has a lot of information

So now while you're slaving away at work you can see the current conditions at the lake just in case you need a mental health break.

Thanks Don!

2024 Board and Committee Chairs

Officer	Position	Officers Flag	E-mail
Zack Lawson	Commodore		Zack@skiersmarine.com
Matt Birckbichler	Vice-Commodore*		mattyb8562@gmail.com
Ed Hurst	Secretary*		Shenanigans770@gmail.com

Elizabeth Starnes	Treasurer*		estarnes245@gmail.com
Chris Edwards	Race Committee		chris@edwards.pub
Pat Upton	Member at Large*		patrickupton@sbcglobal.net
Jeff Wilson	Webmaster		jeffrey. wilson007@gmail.com
Mark Proctor	Cruise Committee		MSProctor2003@yahoo.com
Jenifer Birckbichler	Social Committee		JBirckbichler@gmail.com
Susan Wilson	Education Chair		suhurwil@gmail.com

*Voting Member

Our Dockmaster, Dallas, has been dreaming up an event to get people sailing. Details are sketchy at this time but this is what I think I heard:

The Great 2024 Sail Challenge

The purpose is to get people out sailing at least once every month.

You must leave the Marina and raise your sails at least once every month.

There will be a logbook (Float Plan) to log your trip. You must sign the log book and keep all required safety equipment for you and your guest. The commencement of this has been postponed till February. So that if you went sailing January or February I guess you're in.

\$20/Year to buy recognition and wacky awards at the end of the year.

Ed. Note; I'm not sure what nonsense this entails, But BCSA has no liability in the event-expressed or implied.



LGSC EVENTS 2024

February 10 – Chili Cook Off, Hosted by Yolanda

March 9 – Club Meeting and St. Patrick's Day Celebration, Hosted by Dave Callahan

April 13 – Club Meeting, Browns Creek hosting at BCSC

April 19-20 - Guntersville Cup (Friday Spaghetti dinner \$10 (Beams Hosting with guest hosts George and Trish) and Saturday BBQ dinner for \$15 (Wess Hosting), please RSVP! Breakfast will be provided for Skipper's meeting blessing of the fleet (Scott Hosting)

April 27 – Raft-Up Short Creek Overnight

May 4 – Cinco de Mio party Hosted by Keith and Susan

May 11- Club meeting no social mother's day weekend

May 18 – Mayor's Cup

May 25 – Cruise to Goose Pond, Potluck dinner on dock or Pavilion

May 28 – Return to LGSC

June 8 - Luau party hosted by John Burrows, also hosting BCSC along with swap the tiller race at 1pm please rsvp

June 22 - BCSC Animal Cracker Race

(Lake Guntersville HydroFest June 29-30)

June 29 – Dingy/kayak/canoe Poker Run at the dock and surrounding area

July 4 Thursday– Raft-Up Fireworks leave the dock at 5

2 Shows 1) City Show on Browns Creek

July TBD 2) Bob Barron's Buck Island

July 13 – Club Meeting and Shrimp Boil (Hosted by Debbie & Joe Hosch)
RSVP required

Aug 3 - Cruise Bat Cave and Honeycomb overnight raft up

August 10 – Cruise Club Meeting night out at State Park, hosted by Will and Deb

September 14 – Club Meeting and 2nd Annual Sheila Cole Memorial Dock Walk, Hosted by Sherry & Jerry Wall

September 27-29- TVCC at Browns Creek

October 4-5- Autumn Challenge, Friday lasagna dinner 10\$ Saturday Pot Roast Beef/Pork dinner 10\$ Captains breakfast will be provided

October 12 - Club Meeting Murder mystery dinner theme to be determined
Susan and Keith

October 19-20 - Great River Race (Browns Creek)

October 27 - Halloween Regatta BCSC

November 9 - Annual Dinner hosted by

Nov 27 - WTW and Christmas decorations Wes Webb

December 14 - Christmas Party, hosted by John and Thanh

Please note all Club Meetings start at 4:00 pm except during June, July, and August when they will start at 5:00 pm.

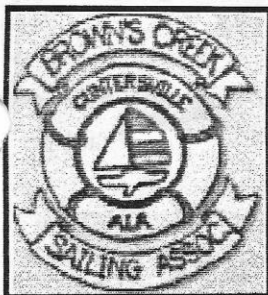

The Drifter

June 1997

The Records and Proceedings of the Brown's Creek Sailing Association

Commodore's Corner

Jim Beecher

The first day of the dinghy series was a wash out, literally. You may recall that the night before there were tornadoes and a cold front that lingered and lingered dumping inches of rain over a small area. Well, the Guntersville area and Tennessee River were right under all that rain.

In the morning, the race committee and competitors arrived to find the seascape much changed. The lake was in full flood stage. Docks were under water, the parking lot was full of water and fit only for parking ducks. A floating marker by the trash dumpster proclaimed "No Wake." Boat owners in boots were walking on the submerged docks to check on dock lines and hoping that they remembered where the dock was. Needless to say, the racing was postponed until a later date.

The clubhouse escaped damage except for water coming down the hill behind the building, through the kitchen door and, after filling the kitchen, running into the main room. Now we know how those stains got on the baseboards and walls.

If you haven't seen the clubhouse recently with all the new repairs, I have to say is that it has never looked better. Next on the agenda, screens for doors and windows.

The second race of the dinghy series fared much better with three races held and eleven boats turning out. A fun time was had by all with only short lulls in the wind.

Do you need a boat trailer? The club has a tilting boat trailer that is available for sale to the highest bidder. The trailer is parked in the south boat trailer lot next to the water. The trailer, suitable for approximately a sixteen to eighteen foot boat, can be recognized by a tall wooden mast cradle, and blue indoor outdoor carpet on one fender. It appears to be strong but will need work to cure the rust. The trailer is offered to the high bidder, where is and as is condition.

Submit your name and phone number with a written bid to BCSEA c/o Jim Beecher, 2501 Galahad Drive, Huntsville, Al 35803. All bids will be reviewed at the next board meeting and the lucky winner notified by phone.

Jim

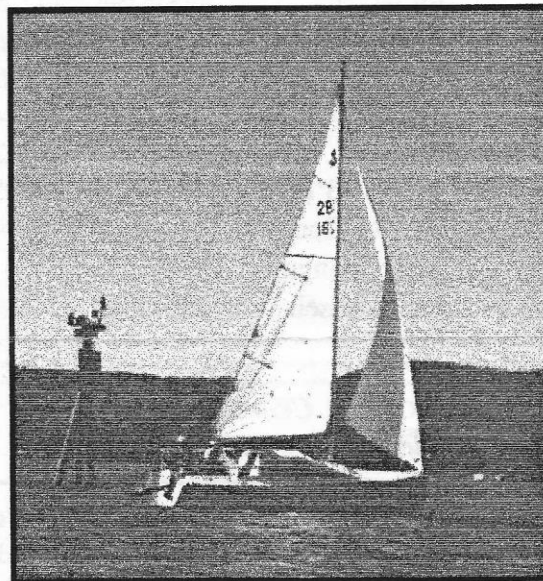

SCHEDULE - AT - A - GLANCE

DATE	EVENT	TIME
June 4	Wednesday Night Race #1	6:30 p.m.
June 7	Dinghy Series #4	9:00 a.m.
June 11	Wednesday Night Race #2	6:30 p.m.
June 14	Couples Race	9:00 a.m.
June 18	Wednesday Night Race #3	6:30 p.m.
June 21	Dinghy Race #1 (rescheduled)	9:00 a.m.
	Dinghy Awards & Pot Luck Dinner	5:00 p.m.
June 25	Wednesday Night Race #4	6:30 p.m.
	Board Meeting	6:30 p.m.
June 28	Snake Island Cruise	10:00 a.m.
	4th Fireworks at Civitan Park on Lake	9:00 p.m.

Skipper's Meetings are at 9 a.m. for all daytime races

1997 OFFICERS			
Office	Name	Home	Work
Commodore	Jim Beecher		
Vice Commodore	John Haskell		
Secretary	Judy Broliar		
Treasurer	Richard Bailey		
Committeeperson at Large	David Green		
COMMITTEE CHAIRPERSONS			
Nominating	Steve Kerkhof		
Race	Matt Blaxton		
	Gus Manguso		
	Randy Fennell		
	Ed Hurst		
Cruise	Phyllis Mullin		
Social	John & Dianne Breyfogle		
Phone	Sam Russell	Hville	
	Bill Wiggins	Gville	
	Pat Holt	B'ham	
Membership	Rocky Gonzalez		
Rules	Nick Mangus		
D.I.Y.A.	Sam Russell		

SOCIAL COMMITTEE
Dianne & John Breyfogle

VICE-COMMODORE
John Haskell

After serving as Race Committee Chairman, the Vice Commodore responsibilities seem small. Buying trophies and keeping BCSA sailors informed about the TVCC are my primary responsibilities. So a reminder, the TVCC will be hosted by the Lake Guntersville Sailing Club (LGSC) on September 20 and 21.

Presently, to the best of my knowledge, all races will be in the vicinity of Seibold Light, unless a separate course is used for the dinghies, which will be in the slough. For your general information, if the schedule is the same as other TVCCs, there will be a skipper's meeting at the LGSC Clubhouse the morning of the 20th, followed by the first day of racing, with dinner at the LGSC clubhouse. The second day of racing will start on the water, followed by trophy presentation at the LGSC clubhouse. Even though it is closer than any other club, it will be a long haul from BCSM to Seibold and back 2 days. Therefore, I plan to leave my boat at LGSC. Now is the time to start making plans. Please, let me know if you plan to take your boat, need crew or would like to crew. If you are taking a boat, will you be in the dinghy, spinnaker or non spinnaker class. Let's have a large turnout and have fun.

Ray Werden with the Coast Guard Auxillary inspected several boats at the BCSA Open House. This is a courtesy inspection, deficiencies are not reported unless a felony is involved (drug possession). Upon successfully passing the inspection a sticker is issued, which when combined with the Alabama Registration sticker will reduce the level of scrutiny by the Marine Police. As an afterthought, I requested an inspection of the General Recall (Race Committee boat). The General Recall had 2 deficiencies which could have been expensive (no registration on board) and a serious deficiency (no throwable life jacket). Ray Werden lives near the BCSA Clubhouse and offered to inspect boats as requested individually. To make arrangements, he can be reached at (205) 582-5022.

I believe the Fireball trailer auction is mentioned elsewhere but some hardware from the Fireball was left over from the Open House sale. The remaining hardware consists of blocks, traveler, bailers and spinnaker equipment. Just contact me for additional information and make an offer. Steve Kerkhof, Ed

The Memorial Day weekend was an overcast and rainy one; but we had a lively crowd for dinner which included some new faces. We feasted on hamburgers, hot dogs, baked beans, cole slaw, chips, soft drink and beer. Dessert was brownies, M&M bars and Judy Broliar's yummy cake!! If you weren't with us; make sure you join us in June.

June 21 there will be a pot luck supper. The club will provide hot dogs, soft drinks, and beer. You bring your favorite or special dish. June 21 will also mark the last of the dinghy series races and awards will be made at the dinner.

June 28 will be the June cruise to Snake Island. Phyllis Mullin says we will leave Brown's Creek about 9:00 a.m.; raft up for lunch and make our way back about dusk for the fireworks on the lake. (Guntersville says that the fireworks will be the Saturday before the 4th) Since this will be a day cruise, remember to bring your lunch and drinks (throw in something for the fireworks watching).

Dianne and John ⚓

Hurst, Terry Williams and I traveled to Oak Ridge for the South East Catalina 22 Regionals May 17 and 18. It was a pleasant trip without incident. I was expecting everything from car to trailer problems. Actually, I had to replace the electrical connector on the car before leaving BCSM. This repair eliminated a leisurely sandwich at Clarence's.

We should be proud of Steve and Ed who placed second. This was quite an accomplishment when considering the level of competition at Oak Ridge. Several of the top competitors from the Catalina 22 Nationals were at Oak Ridge.

With Dianne Breyfogle's help, I finally tackled the old Drifters, to document the Overall Great River Race Winners for the Perpetual Trophy. Here is the latest, we are getting close to engraving the trophy. So as always please review the list and provide corrections.

- 1970 JIM BATSON
- 1971 GEORGE PEDIGO
- 1972 JIM BATSON
- 1973 CLARK SOUTHARD
- 1974 CLARK SOUTHARD
- 1975 BOB MORGAN
- 1976 BOB MORGAN
- 1977 NORM WALKER
- 1978 NORM WALKER
- 1979 BILL SWARTZ
- 1980 AL SEARWAY
- 1981 JEFF HOOMANI
- 1982
- 1983 WAYNE MILLER III
- 1984 WAYNE MILLER III
- 1985 STEVE PFEFFIER
- 1986 CECIL HAZEN
- 1987 BOB HODO
- 1988 MIKE GORDON
- 1989 MIKE GORDON
- 1990 MIKE GORDON
- 1991 RUSSELL CARRINGTON
- 1992 RUSSELL CARRINGTON
- 1993 MIKE GORDON
- 1994 RUSSELL CARRINGTON
- 1995 PAT HOLT
- 1996 DON LOVELACE

ON THE WEATHER RAIL
Jim Beecher

This year has certainly been the busiest on record for me. Mom broke her arm in late December, then spent a January week in the hospital for blood clots in the leg requiring over a month of rehabilitation on arm and leg. Then there was closing and moving the old apartment, opening a new place, and storing a lifetime of furnishings and possessions. Add to that my family, a busy business schedule, and a house to care for. My plate was overflowing!

The point is that sailing helped me get through it all. When I was able to get away to go sailing or just go to the lake to work on the boat (infrequently I assure you) I was able to really relax and enjoy myself. I can't explain exactly what it is, but when I sail or am just near the water, my mind doesn't think of the daily cares and problems that we all face. A stressful job and busy home life tend to build and build until you can't think of anything else. But when I am sailing, those cares are put aside. The sound of the moving water and wind in the sails forces you to think only of the boat and sailing. To me nothing is more relaxing than to be on a boat.

Actually, I was the race committee this past weekend and in spite of the need to move the marks and the boat for each race, I had a great time. In fact, I brought a news paper and books to read but after the first race there was no interest in reading. Just enjoying the weather, watching the boats, the sea birds and relaxing was wonderful.

If you have a boat, take advantage of it. Come on down to the lake. Take advantage of the cruising planned for this summer to see the lake at all times of the day. If you race, have fun racing but take the time out for cruising and our social programs. Take an old friend to the lake and introduce them to sailing, or better still, take a new friend out on the water and make them into a life long friend. I know it works. Try the sailing life.

I hope to see you on the weather rail real soon.

Jim



John



RACE COMMITTEE

Matt Blaxton

Another month has come and gone and my boat is still in the driveway. The hull is still drying. At least that's my excuse and I'm sticking to it. My list of things to do was really long when I first took it out of the water, but with not much of the list done I have prioritized what I have to do before putting it back in the water. My list is as follows: patch blisters, paint, dry (maybe), sail. Well, on to the racing report. . .

Due to unfortunate circumstances beyond our control, we had two races cancelled this last month. The Animal Cracker Regatta was not run and will not be rescheduled. Dinghy Series #1 was cancelled and will be raced on June 21, 1997. Since this race will be the last dinghy race, the potluck supper will be rescheduled for June 21. For those that still want supper at Dinghy Series #4, I'm sure Clarence's BBQ will be happy to fill your take-out or dine-in orders. Domino's will also deliver now that they have discovered where the clubhouse is located.

Dinghy #2 had a fantastic turn-out with eleven boats! Somewhere in this DRIFTER you will find the point totals. Handicaps and time details will be posted at the clubhouse by May 31, 1997 (if I can still find my way there).

Matt ⚓

CRUISE COMMITTEE

Phyllis Mullin

Party and Cruise Schedule

- June 21 Pot Luck Dinner after Dinghy Race
June 28 Cruise - Snake Island (Named
for the shape of the island, not the inhabitants!!)
(Guntersville Fireworks at the Lake)
July 5 Fire Cracker Regatta Dinner*
July 12 Cruise - Honeycomb
July 26 Cruise - Little Mountain Lakes Resort
August 9 Cruise - Bon Fire Cove
August 16 Cookout/ Family Day
September 13 Spaghetti Supper
September 27 Cruise - TBD
October 3 Great River Race Dinner

*reservations necessary so we will know how many dinners to order.

Phyllis ⚓

Some Rambling Notes on the Virgin Islands

Bill Stevenson

The Virgin Islands are hot but there is generally a breeze.

The town of Charlotte Amalie is a lot like an English Village. People drive on the wrong side of the road and speak with a strange accent.

The ferry schedule changes a lot.

The native women wear brightly colored dresses.

None of the stores charge sales tax.

Island Time: within twenty minutes of the stated schedule, more or less. Ferries and restaurants run on Island Time. Planes do not.

People call you "honey" a lot.

The taxi drivers are friendly.

People say "not a problem" a lot.

Earplugs make a real difference if one of your party snores.

The Wednesday morning ferry to Tortola is not crowded. The Wednesday morning ferry back to St. Thomas is.

Food prices on Tortola are high, but no worse than at the coffee shop in the Huntsville Airport.

When it comes to boat maintenance, Sunsail, unlike Ford, does not sweat the details.

Eighty gallons of water seems like a generous amount for a boat crew.

It is surprising how much water can leak from a defective water tank when a sailboat heels in a breeze.

Forty gallons of water seems like a small amount for a boat crew.

It only takes about ten minutes to ladle and sponge water out of a flooded cabin.

Drying the mattress takes longer.

⚓⚓⚓

The bad news: There's not much breeze in the Sunsail marina at night.

The good news: The cabins have fans.

The bad news: Earplugs don't seem to work against the sound of a rattling fan.

The good news: There's a nice breeze at all the other stops.

It takes three days to fully drain a defective water tank by heeling a boat in a breeze.

A mainsail that winds inside the mast seems like a real convenience, until it jams.

(Bill, cont.)

The water at The Caves is rather hazy by BVI standards. By Lake Guntersville standards, it is remarkably clear.

Fish in the BVI do not wish to shake hands with a snorkeler.

⚓⚓⚓⚓

The water is colder than it looks.

The sun is as strong as it looks.

Waterproof sunscreen isn't.

Sunsail must buy their snorkels on sale.

Washing your hair in the ocean saves a lot of fresh water.

Wouldn't you think that a 45 rated sunscreen would last 38 minutes in the water?

Navy blue leotard style biking pants work really well to prevent sunburn and chills while snorkeling.

A 1996 Great River Race shirt works pretty well, too.

Which would you think would attract more attention on a beach - a pretty girl in a bikini or a skinny guy wearing navy blue leotards and a 1996 Great River Race shirt?



⚓⚓⚓⚓
Nude bathing seems to be legal in Mancioneel Bay.
Coconut is a popular name for boats in the BVI.

⚓⚓⚓⚓

A frozen steak takes an extra ten minutes to cook.
Making a soft boiled egg is not as easy as you might think. It takes two engineers and a chemist three tries to get it right.

There are many goats in the hills of the BVI.

Rum is cheap in the Virgin Islands.

It is surprising how well a goat's voice carries across the water at night.

Sunsail must buy their dinghies on sale.

⚓⚓⚓⚓

The waitress at The Last Resort wears a really short skirt.

The bad news: The lock on a Sunsail dinghy cannot be operated by any key known to man.

The good news: No one will try to steal a Sunsail dinghy.

The waitress at The Last Resort goes barefoot.

The barmaid at The Last Resort has a cute accent.

An Oceanis 351 steers nothing like a Laser.

⚓⚓⚓⚓

They really like cats at The Last Resort. And dogs.
And parrots. And jackasses.

A donkey's fur is softer than you might think.

The waitress and the barmaid at The Last Resort look like sisters. They also look about fifteen.

Donkeys like to eat broccoli.

The owner of The Last Resort knows some good sailor jokes.

A donkey has a hard time telling the difference between a broccoli stalk and a person's finger.

Some Cuban cigars would take me the better part of a week to smoke. And to pay for.

A Tupperware container full of marmalade does not travel well.

The U.S. Customs department really hates Cuban cigars.

⚓⚓⚓⚓

On a BVI sailing cruise you will see no TV, read no newspapers, and completely lose track of politics and the stock market.

Talk about paradise.

Bill



1997 BCSA Group Charter
Amy Gonzalez

The 1997 BCSA Group Charter to the British Virgin Islands has come to a close, but the memories will last forever! Everyone seemed to have a great time sailing and exploring the islands. We hadn't met some of the charterers in our group until the trip, and now we feel we've made some new friends. With the launch from Soper's Hole on Tortola, each boat chartered their own course depending on what they wanted to see and do in the BVI. Radio contact allowed some of us to join up for afternoon and evening activities on one island or another. Each sailor's charter experience was unique with each of the six boats setting their own activities. This article attempts to snapshot our charter experiences with a 38-foot catamaran, "Dimitile". Hopefully other's will also share their chartering stories with you, too.

Our trip began with a group flight from

Huntsville to San Juan where we met up with Claude and Simone Carrier who were joining us from Florida. Our landing at Beef Island Airport on



Crusin' BCSA

Tortola was smooth, but I can't say as much for our open-air truck/taxi ride to Soper's Hole. It was pretty exciting... gulp! Some of us likened it to the "Mr. Toad's Wild Ride" at Disney World. We made it, checked into the Sunsail hotel for the night, and enjoyed a group dinner at Pusser's Landing Restaurant. The guitars came out of their duct tape encasements, were tuned up, and carried us into the night.

Sunsail's efficient crew at Soper's Hole managed to get us briefed on the local waters and off the

dock earlier than expected on Wednesday afternoon. Some of our group traveling through St. Thomas arrived at the base later on Wednesday and left Soper's Hole early Thursday morning. We chartered a 38-foot catamaran, with four cabins, for eight sailors. We were quite pleased by the roominess of this boat. Our first night afloat was spent in Little Harbour on Jost Van Dyke. Several of us hit Sidney's Peace & Love for some lively tunes and the self-serve bar.

Thursday found us back at Soper's Hole for a brief stove check and then on to the Bight at Norman Island. We couldn't resist having dinner at the William Thornton floating restaurant (a converted Baltic Trader) and wound up the evening wishing Mary Miller a happy birthday on their boat, "Monique". The next morning brought plenty of snorkeling as we visited both the Caves (part of Norman Island) and the Indians (large, steep rock formations just outside the Bight by Pelican Rock). Friday evening was spent in Road Town (the capital), with dinner at The Pub and a

breezy night at our mooring. Saturday morning brought sudden excitement as a nearby catamaran's anchor lost it's hold and headed our way.

The cat's crew was ashore as Rocky and John boarded the wayward boat to save our Dimitile and other nearby boats from disaster. The crew arrived during a wind shift to motor their boat to safety.

With everyone now wide awake, we headed out of Road Town for a beautiful sail to the Baths of Virgin Gorda. The Baths, on the southwest end of the island, were incredible huge boulders scattered along the edge of the island forming grottoes at the water's edge. We enjoyed climbing through the boulders and consider

this a place definitely worth another visit one day. Overnight moorings were not allowed at the Baths, so we continued north to an anchorage just off Spanish Town.

Anegada is the northern-most island in the chain and only recently became available to the chartering crowd. The many reefs surrounding the island have claimed over 300 known vessels. With our Sunsail guide, Bill, on the Wayne Blaxton's lead boat ("Amanje") we safely enjoyed the sail to Anegada. The day's trip was highlighted by the antics of our local pirate, Claude, howling and yipping as the catamaran easily passed our companion monohulls. One quickly learned in the BVI that the most reliable way to eat ashore was to not only make early reservations, but to place your food order as well. The Anegada Reef Hotel came highly recommended, but was no exception to the rule. Their specialty was lobster mmmmmm! With dinner arrangements made, some of Monique's crew and I took a wild truck ride to the northeast side of the island to snorkel at Loblolly Bay. We returned in time for a great dinner served at tables on the beach. Very nice!

The next morning as the other boats headed south, we took Tony's Taxi for more underwater exploration of Loblolly Bay and the Flash of Beauty Bay. After lunch we sailed to the Bitter End Yacht Club on Virgin Gorda to join the others. What a beautiful resort! The lushly landscaped BEYC catered to just about anything a visitor would want to do on or in the water. (I heard that a BCSA burgee now resides at the BEYC!) The evening rocked to the steel drum band. BCSAers started a dance pit in the sand behind the band, enticing others to join.

The nights dancing drew to an end shortly after the conga line threaded through the sand pit, tables and gazebo. What fun!

Tuesday provided a most enjoyable sail past Tortola towards Jost Van Dyke. As a brief storm brewing over the island headed our way, a stiff wind came up affording us our record speed of 15 knots on the cat. Claude was at the helm as the crew gathered to excit-

edly watch the speed increase. One by one we gathered around our helmsman, chanting with each new record! The ruckus stirred Rocky from below decks, who quickly agreed with Cameron that the main should be reefed a little more for the impending weather. Oh well, it was exciting while it lasted!!

On our way to Great Harbour for the night, we took time out at Cane Garden Bay, Tortola to briefly visit the unique 200-year-old Callwood Rum Distillery. Of course we had to buy some samples to take home! Our last night of the charter was spent at Foxy's, with Rocky, Matt, and John providing musical entertainment since Foxy himself couldn't make it. We had a restaurant full of international sailors rocking and dancing to the tunes from our very own acoustic trio! What a way to end the voyage. Foxy's son, Neal, showed up later in the evening to entertain our group with his guitar and unique comical tunes, as well as jokes for all. The BCSA burgee was hung from the rafters of Foxy's that night. (Note: The manager encourages any BCSA members to sign the burgee when they visit in the future...if you can reach it!)

The Sunsail base at Soper's Hole awaited our return on Wednesday morning. We said our good-bye's to some of our sailing companions at the docks as we went our separate ways, each carrying a boatload of tropical memories of good times in the BVI.

To the 33 sailors of the 1997 BCSA Group Charter: I hope you all had a wonderful trip. Rocky and I certainly did...and look forward to the next one!

Amy 

**Be sure to let Dianne Breyfogle
know if you plan to be at the
Firecracker Regatta dinner.
We need reservations because
we are planning to have it
catered.**

Deadline for Drifter articles is the 20th of the month.

You may e-mail them to Judy Broliar:

**broliar@ro.com or mail them to
7806 Hilton Drive, Huntsville, AL 35802**

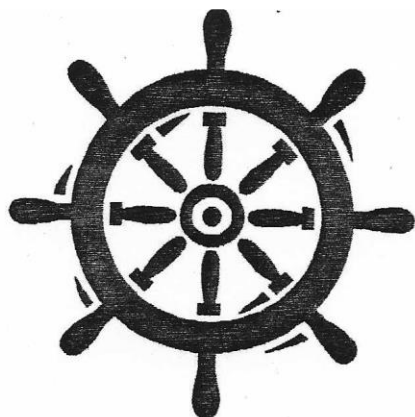

Race Results

Dingy #2 Standing

Skipper	Boat	Race 1	Race 2	Race 3	Total
Roy Waldrup	Thistle	1	1	1	3
Gus Manguso	Buccaneer	2	3	2	7
Sam Russell	Laser	3	2	3	8
Connie Carrington	Laser	6	4	6	16
Greg Jones	Coronado 15	7	5	7	19
Vaughn Wamer	Sunfish	8	7	4	19
Larry Fisher	Buccaneer	4	8	8	20
Terry Marti	Comet	9	6	9	24
Randy Fennell	Kestrel	5	11	10	26
???	Hobie 16	12	12	5	29
Allen Markel	Laser 2	10	10	11	31
Chuck Taylor	Coronado 15	11	9	12	32

Celebrate at the Lake

Firecracker Regatta July 5th & 6th

Social July 5th 5:00 p.m.

Dinner 6:00 p.m.

(reservations to Dianne Breyfogle @ 582-2438

or e-mail breyfogle@localaccess.net



*Our ex-Commodore, His Excellency-Pat Upton seen here in his winter attire “dressed ship” for Margaret and my wedding.
Marine Signal flags, each corresponding to a letter are easy to read.
If you can spell your name and you know the Racing Signals you can read them.
I’ve got a free beer for the first six people who can tell me the message.*